



# RIVA RACING

PERFORMANCE PRODUCTS & ACCESSORIES

## Sea-Doo 4-TEC Open Loop Cooling Kit

**PART# - RS1013-50**

We strongly recommend the use of a service manual to familiarize yourself with the various components and procedures involved with this installation. Please note that some of the original clamps, hoses and hardware removed in the disassembly process will be used in the installation process. These instructions have been written in point form and refer to illustrations. Please follow these step-by-step instructions and illustrations carefully. Water routing illustrations are provided as a reference during installation.

**APPLICATION(S):** 255/215hp Sea-Doo Models

**\*\*\* ALLOW ENGINE TO COOL COMPLETELY BEFORE PERFORMING INSTALLATION \*\*\***

### **Required tools**

Oetiker Pliers  
E-8 Star Socket  
Dremmel Tool  
Drain Pan (LG)  
Service Manual

### **Part#**

C-84550347  
RS90531 (8-pc set)  
N/A  
N/A  
CALL

**NOTE: Water routing is designed for engines running up to 8,650rpm. If engine is run above 8,650rpm water pressure to intercooler must be reduced or restricted to prevent damage.**

## **- INSTALLATION INSTRUCTIONS -**

Remove seats.

Drain engine coolant following steps outlined in the Sea-Doo Vehicle Shop Manual (4-TEC Manual). *Please recycle or dispose of coolant properly!*

### **Coolant expansion tank holder removal.**

#### **RXP-X/RXP Models Only:**

Unclip engine coolant overflow tank. Disconnect hoses and remove overflow tank.

Remove engine compartment cowling (5 bolts).

#### **RXT-X/RXT:**

Unclip engine coolant overflow tank. Disconnect hoses and remove overflow tank.

Remove engine compartment cross section (4 bolts).

At pump disconnect steering cable<sup>1</sup> and reverse cable<sup>2</sup> from steering nozzle. Disconnect VTS rod<sup>3</sup> from VTS motor rod<sup>4</sup>.

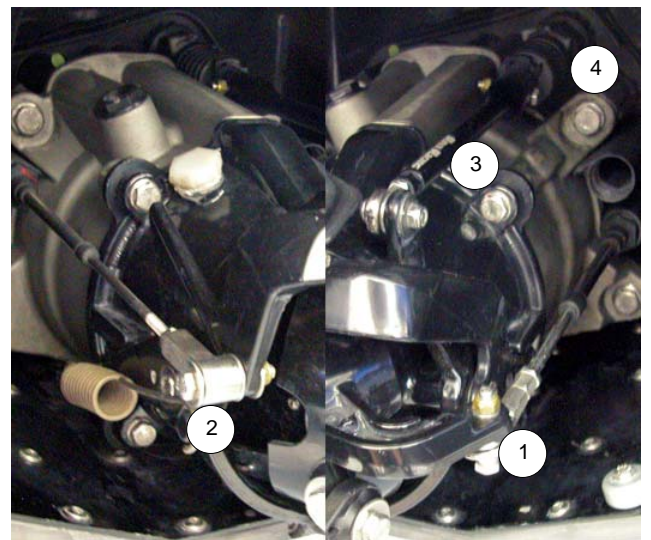

If O.P.A.S. was removed previously proceed to next step. Otherwise remove bolt securing O.P.A.S. bracket to underside of steering nozzle.

Remove bolts (4) securing pump assembly to hull.  
Remove pump assembly.



Remove rubber boot sealing VTS motor shaft. Remove nut securing VTS motor unit to hull.

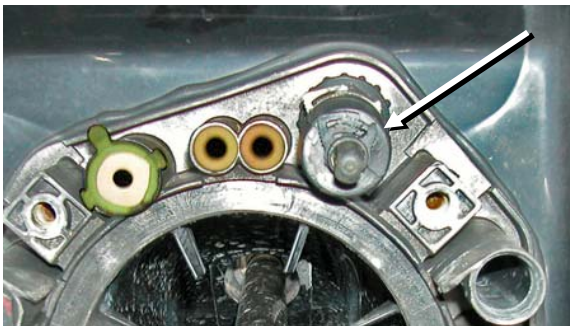

If using a RIVA Pro-Series Water Box proceed to next step. Otherwise remove exhaust tube between water box and thru-hull outlet.

Remove intercooler air inlet and outlet tubes.

Loosen the four bolts securing throttle body to intake manifold. Remove throttle body and move forward in engine compartment.

Remove the two bolts securing front of RIVA Power Filter tube to engine bracket. This will allow you to move Power Filter tube as needed during installation process.

Inside hull remove VTS motor unit from thru-hull fitting and move forward in engine compartment.

Disconnect hoses (6) connected to thermostat housing. Completely remove all hoses except for the two connected to oil cooler (#'s 3 & 5).

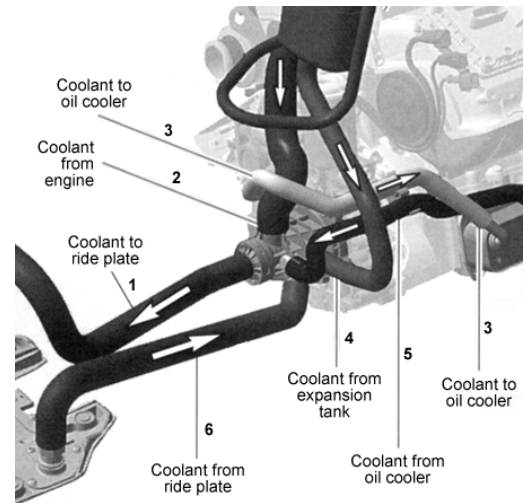

If a RIVA Performance Ride Plate will be installed proceed to next step. Otherwise, install supplied vinyl caps over stock ride plate fittings and secure using supplied zip ties.



Install the supplied sacrificial zinc anode into the supplied billet water pump cover.



Remove bolts (8) securing thermostat housing to engine. Remove thermostat housing from engine.

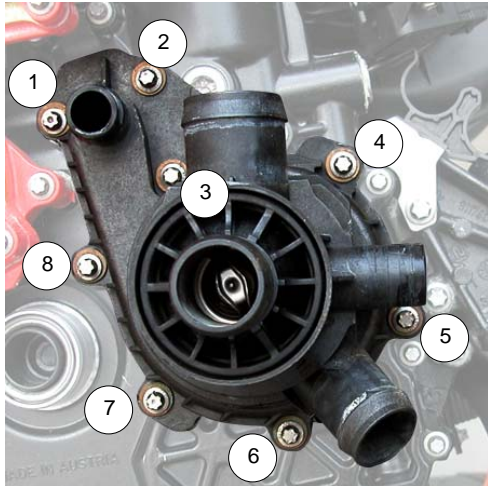

**NOTE: Do not remove impeller from engine.**

Transfer o-ring from back of thermostat housing to back of supplied billet water pump cover.

Apply a thin coat of grease to o-ring. Install billet water pump cover onto engine and secure using OE bolts. Torque to 89 lbf•in / 10 N•m. **NOTE: Apply r Loc-tite to bolts.**

At rear of cylinder head remove the barbed brass fitting for coolant overflow hose. Install supplied stainless steel block-off screw.



**NOTE: Apply pipe thread sealant to threads. Tighten screw until head is flush with cylinder head.**

Install supplied thermostat unit onto rear of cylinder head. Secure using the supplied 47.0 Oetiker.



#### Cooling Line Removal:

**255hp Models Only:** Locate and completely remove cooling lines with 'T' fitting coming in from transom to intercooler and exhaust manifold<sup>1</sup> as well as cooling lines with 'T' fitting going to transom from exhaust manifold and intercooler<sup>2</sup>.

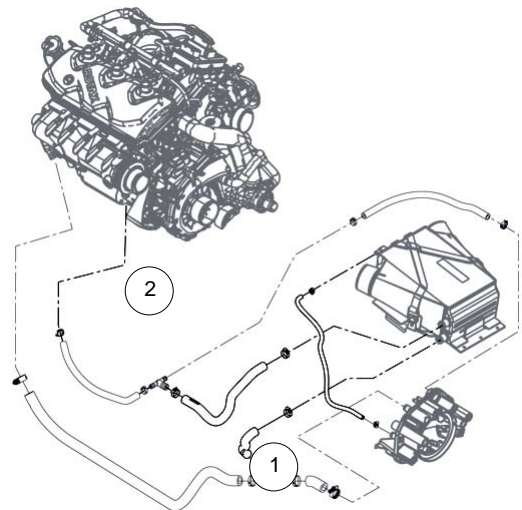

**215hp Models Only:** Locate and completely remove the cooling lines from transom to intercooler and from intercooler to exhaust manifold.

Locate and remove 3/8" waterline between top of 'J' pipe and transom<sup>1</sup>.

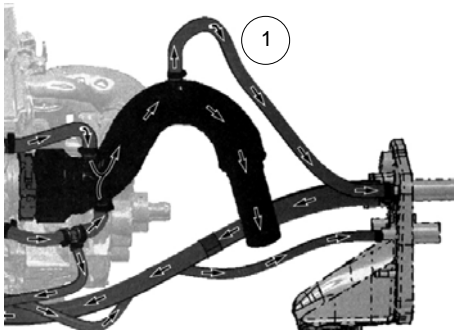

Install supplied 3/4" bypass fitting.



**NOTE:** Enough cooling line is provided so that bypass can be installed in transom near rear exhaust outlet. However, bypass can be installed in pump transom tunnel if desired.

Install supplied 3/4" cooling line assembly (labeled 'A') between the intercooler and motor. The 15" length<sup>1</sup> attaches to billet water pump cover. Secure with stock hose clamp. The 33" length<sup>2</sup> attaches to fitting at front of exhaust manifold (route under drive shaft and motor). Secure with stock hose clamp.

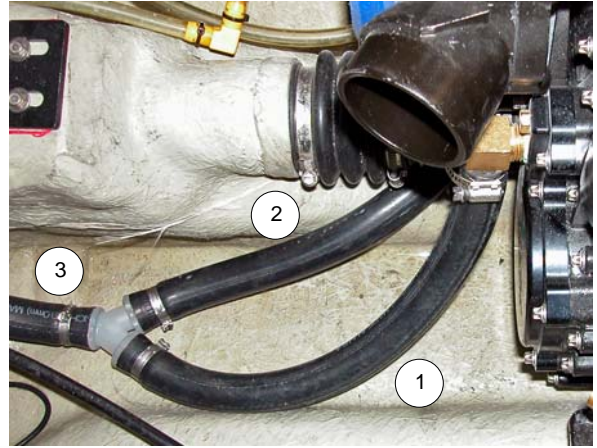

Route open end (14" length<sup>3</sup>) towards intercooler support bracket.

Install supplied 3/4" cooling line assembly (labeled 'B'). Attach 24" length<sup>1</sup> to transom inlet fitting. Route 12" length<sup>2</sup> towards intercooler. Route flush kit<sup>3</sup> so it can be secured in an accessible location.



Attach 3/4" cooling lines to intercooler. Secure with stock hose clamps.



- 1- Line in to intercooler from transom/flush kit.
- 2- Line out from intercooler to motor.



- 3- Line in to intercooler from transom/flush kit.
- 4- Line out from intercooler to motor.

Replace intercooler and secure to support bracket.

On right side of engine cut oil cooler lines just before support bracket<sup>1</sup>. Install supplied 1/2" x 5/8" brass hose splicer into each hose and secure using supplied 25.6 Oetikers.

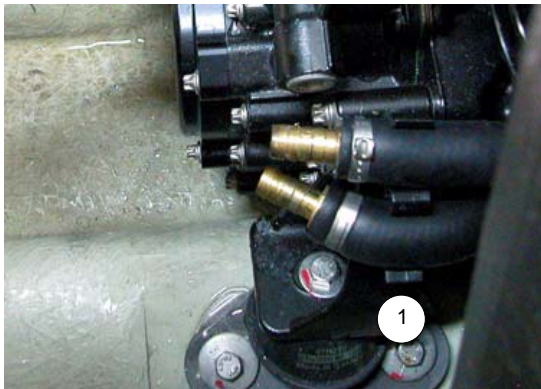

**NOTE:** Larger end of splicer goes into oil cooler hose.

Install supplied 24" length of 1/2" waterline between lower cooling line<sup>1</sup> (oil cooler outlet line) and 3/8" transom fitting<sup>2</sup>. Secure to oil cooler line using supplied 21.0 Oetiker. Secure to transom fitting using stock hose clamp.

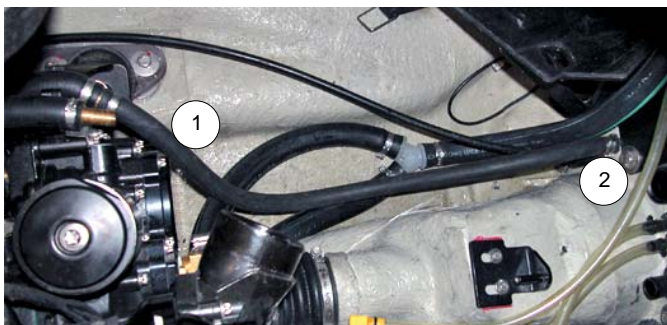

Install the supplied 36" length of 1/2" waterline to the upper cooling line<sup>3</sup> (oil cooler inlet line). Secure using supplied 21.0 Oetiker.

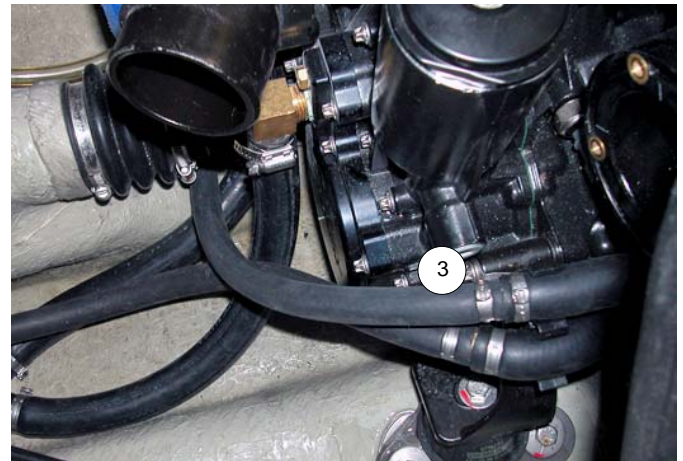

Route waterline under drive shaft and towards exhaust pipe/water box joint.

Attach to applicable fitting (see below) and secure using stock hose clamp. Trim excess as needed.

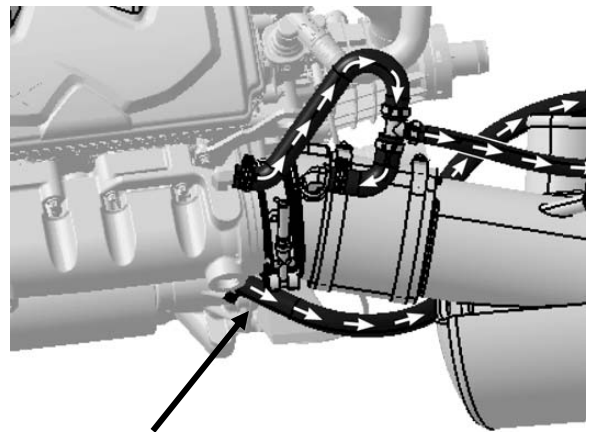

'08 & newer attach to fitting under end of exhaust manifold.

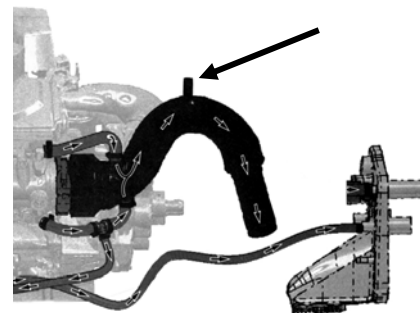

'07 & older attach to fitting at top of 'J' pipe (trim excess as needed). Secure using stock hose clamp.

Replace VTS motor unit into thru-hull fitting making sure rubber grommet at bottom of housing is installed onto VTS mounting bracket.

At rear of craft in pump area replace and secure VTS motor nut. Replace and secure rubber boot sealing VTS motor shaft. **NOTE: Do not over tighten nut.**

Replace Power Filter Tube. **NOTE: Apply blue Loc-tite to bolts. Do not over tighten bolts. Do not over tighten clamps.**

Replace throttle body and secure using OE bolts. **NOTE: Torque bolts to 11 N•m (97 lbf•in) in a criss-cross pattern.**

Install 36" length of supplied 3/4" cooling line between thermostat on cylinder head and 3/4" bypass fitting in hull. Trim excess as needed. Secure to thermostat using supplied 30.1 Oetiker. Secure to 3/4" bypass using stock hose clamp.



Replace supercharger air inlet components. **NOTE: Do not over tighten bolts.**

Replace intercooler air inlet and outlet tubes. **NOTE: Do not over tighten bolts.**

If using a stock water box replace exhaust outlet tube. **NOTE: Do not over tighten clamps.**

At rear of craft in pump area replace OE water inlet reducer with supplied reducer.



**NOTE: Supplied water reducer has a larger I.D. and is stamped with an 'X' on one side.**

If a RIVA Performance Ride Plate will be installed continue with the instructions included with ride plate. Otherwise, apply glass cleaner to rubber seal on pump assembly. Install pump into craft and secure using supplied bolts. **NOTE: Apply blue Loc-tite to bolts. Torque to 31 N•m (23 lbf•ft) in a criss-cross pattern.**

Reconnect VTS rod, reverse cable and steering cable. **NOTE: Do not over tighten bolts.**

If O.P.A.S. was removed proceed to next step. Otherwise, reconnect O.P.A.S. bracket to steering nozzle. **NOTE: Use blue Loc-Tite. Torque bolt to 25 N•m (18 lbf•ft).**

#### **RXP-X/RXP Models Only:**

Replace engine compartment cowling (5 bolts).

#### **RXT-X/RXT:**

Replace engine compartment cross section (4 bolts).

Check bilge for tools, rags, etc. Run craft on flush kit to check for leaks and to ensure smooth operation.

# **IMPORTANT MAINTENANCE INFORMATION**

**Flushing:** To assure optimal performance with this kit extra care must be used with flushing. The Open Loop flush connector will be used in place of the stock flush kit fitting in the pump. We **strongly** recommend the use of a salt /deposit remover such as [Salt-Away®](#) which can be purchased through RIVA Racing's parts department. When flushing with a salt/deposit remover do not flush with fresh water afterwards. Allow salt/deposit remover to remain in cooling system. This will prevent build up of salt or deposits from residual water in cooling system. At the end of your riding season we recommend "winterizing" your craft if you are unable to ride for an extended period of time.

**Sacrificial Anode:** Open Loop Cooling Kit water pump cover is equipped with a sacrificial anode. This is to prevent corrosion from occurring in the motor should you "forget" to flush your craft. However, it is not intended to be used as an alternative to flushing your craft. Anode will deteriorate over time and should be replaced each season or as needed. Check anode at beginning and end of riding season. When replacing apply pipe thread sealant to threads and do not over tighten. Replacement anodes are available through RIVA Racing's parts department.

***Remember, the water belongs to everyone.  
Please ride responsibly and respect the environment!***

## **Technical Support**

For answers to questions regarding installation or trouble shooting RIVA Performance Products contact:  
RIVA Technical Support directly at (954) 247-0705 or by e-mail at [tech\\_support@rivamotorsports.com](mailto:tech_support@rivamotorsports.com).

## **Limited Warranty**

RIVA Open Loop Cooling Kits carry a 1-year limited warranty to the original purchaser. They are warranted to be free of defects in materials and workmanship under normal use and service. Customer modified components will be void of warranty. This warranty is limited to defects in the primary components only. Finish and/or wear marks in or on primary components are not covered under this warranty.

RIVA Racing's liability is expressly limited to the repair or replacement of the components contained within or associated with this kit. RIVA Racing agrees to repair or at RIVA's option, replace any defective unit without charge, if product is returned to RIVA Racing freight prepaid within the warranty period. Any equipment returned which, in RIVA's opinion, has been subjected to misuse, abuse, overheating or accident shall not be covered by this warranty.

RIVA Racing shall have no liability for special, incidental or consequential damages or injury to persons or property from any cause arising from the sale, installation or use of this product.

No other warranty, express or implied, including, but not limited to the implied warranties of merchantability and fitness for a particular purpose, applies. Various states do not allow for the limitation of incidental or consequential damages and therefore the above exclusion or limitation may not apply to you.

Warranty does not include the expenses related to freight or transportation of parts or compensation for any inconvenience or loss of use while being repaired. A copy of the original invoice and a Return Authorization Number (RA#) must accompany all warranty claims.

Warranted replacement parts will be returned freight collect.

## 255hp Intercooler Upgrade Kit & 215hp GEN-2 Power Cooler Kit Water Routing Illustration

